

DESCRIPTION:

Vacuum breaker in complete stainless steel construction. Best suited for heat exchanger, jacketed kettles, liquid process lines, chilled water lines, Boiler feed water lines and air coils.

FEATURES:

PVB10 is designed to allow air into condensing steam or liquid systems where the creation of a vacuum would be harmful, inhibit flow or drainage, and decrease system performance & efficiency.

SIZES:

System connection: DN15

Air inlet connection: DN8, 10, 15

CONNECTIONS: Screwed (NPT/BSPT/BSP)

LIMITING CONDITIONS:

PMA: Max. allowable pressure	21 bar(g)
TMA: Max. allowable temp.	450 °C
Minimum vacuum required for opening	0.005 bar(g) (50 mm of H ₂ O)
Cold hydro test pressure	42 bar(g)

INSTALLATION:

The vacuum breaker should be installed vertically with the cap at the top & at the highest point of the system. An isolation valve needs to be fitted for facilitating servicing.

MAINTENANCE:

After the vacuum breaker is isolated from the system, unscrew the top cap & examine for any wear/tear & debris on ball or seat which could cause leakage. Clean and refit. With the exception of possible cleaning, this device is maintenance-free. Vacuum breakers are not repairable on-line.

AVAILABLE SPARES:

No spares available.

HOW TO ORDER:

PVB-10 DN15 DN8 BSP

ORDERING INFORMATION:

- 1) Inlet Pressure in bar (g)
- 2) Size & Model
- 3) End Connections.

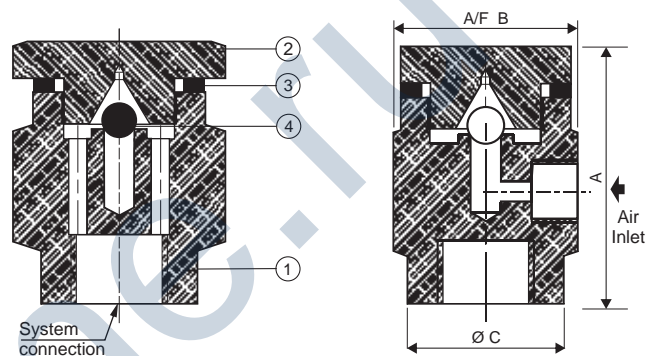

DIMENSIONS - Nominal in mm

SIZE	A	B	C	Wt.
DN15 x DN8	55	37	32	0.375 kg
DN15 x DN10	60	37	32	0.400 kg
DN15 x DN15	70	49	32	0.550 kg

MATERIAL

No.	PART	MATERIAL	QTY. (Nos.)
1	BODY	AISI 304	1
2	CAP	AISI 304	1
3	BALL	AISI 304	1
4	GASKET	NON CAF	1

AIR HANDLING CAPACITIES

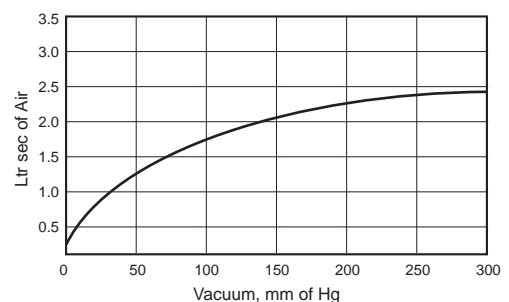

Local regulations may restrict the use of this product below the conditions quoted. Limiting conditions refer to standard connections only. In the interest of development and improvement of the product, we reserve the right to change the specifications without prior notice.